

Augmented Reality:

what is it and how can I use it?

Dr. Laura Huisinga
Assistant Professor
Fresno State University



What is AR?



“as a digital display that blends virtual graphics with a physical reality” (Vyas, 2015)

**Vyas, D. (2015). Increasing student engagement using
Augmented Reality. The Journal of Educational Innovation,
Partnership and Change, 1(2).**

The terms AR “describe[s] a digital display that blended virtual graphics with a physical reality” (Vyas, 2015).

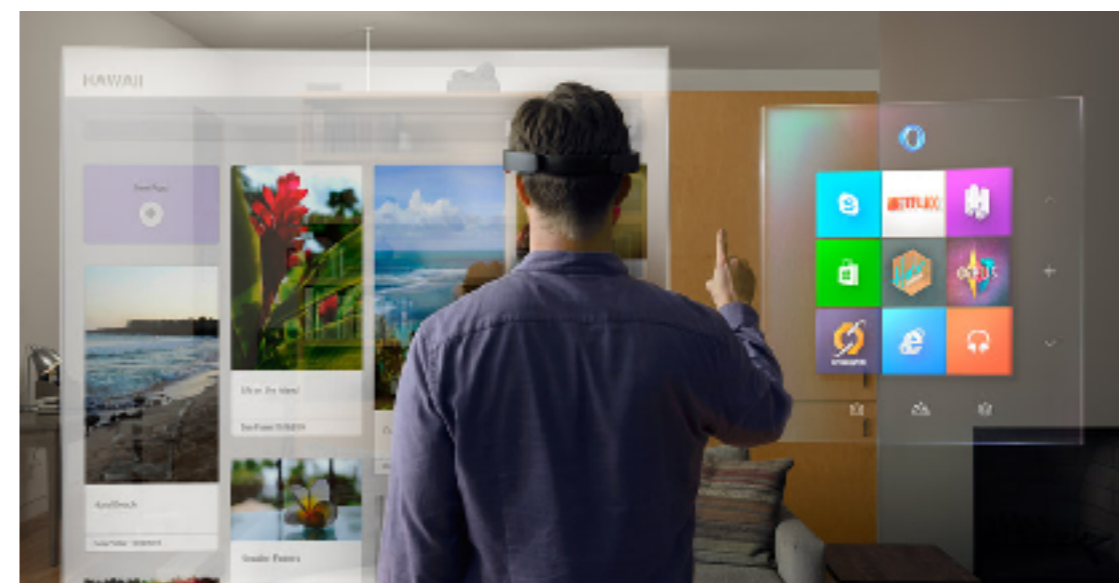

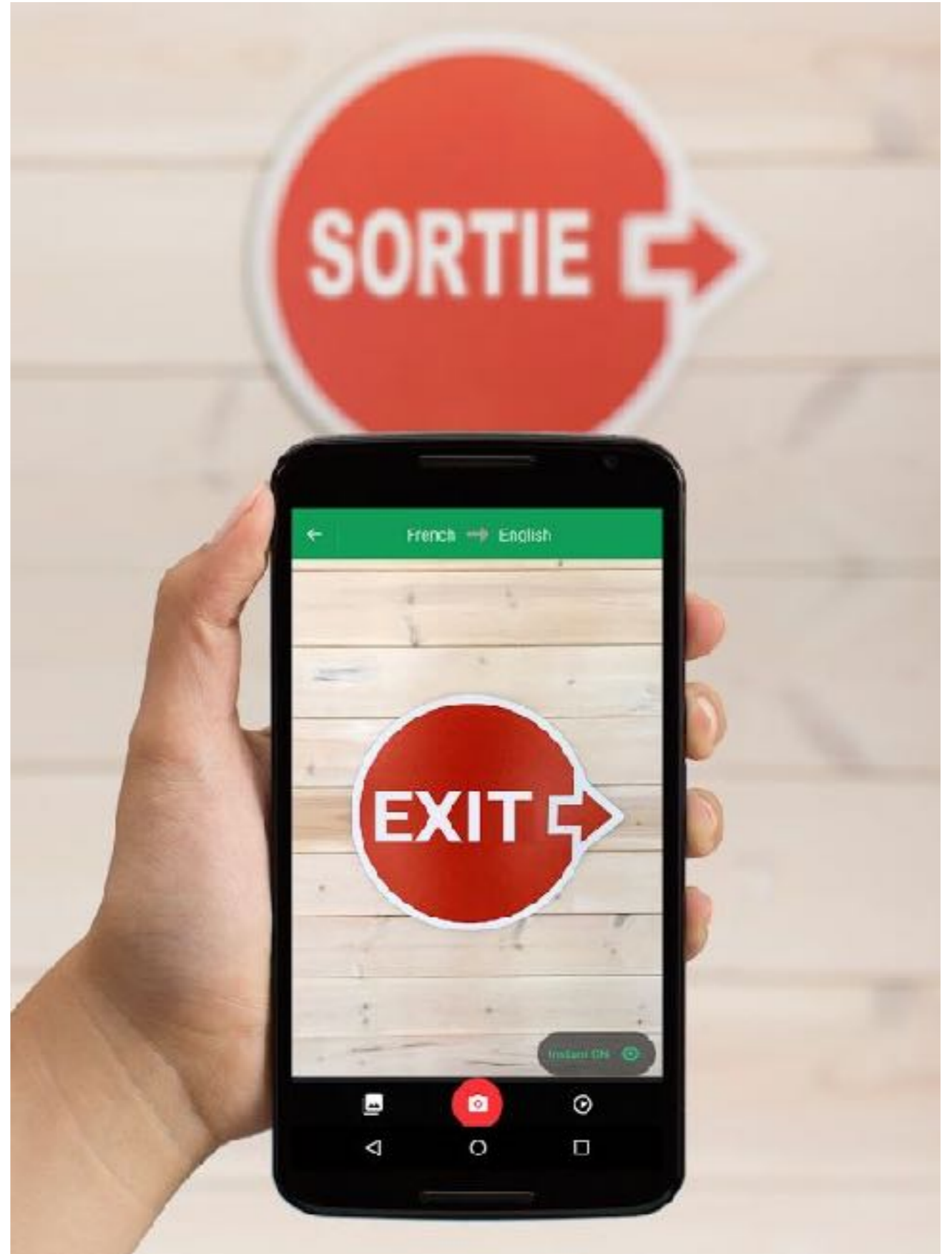



History of AR



1957-1962: Morton Heilig builds the Sensorama, a cinematic experience to engage all the senses.

1968 The Sword of Damocles was the nickname of the world's first head-mounted display. Courtesy of Ivan Sutherland.







Augmented reality, mixed reality and virtual reality Whats the difference?

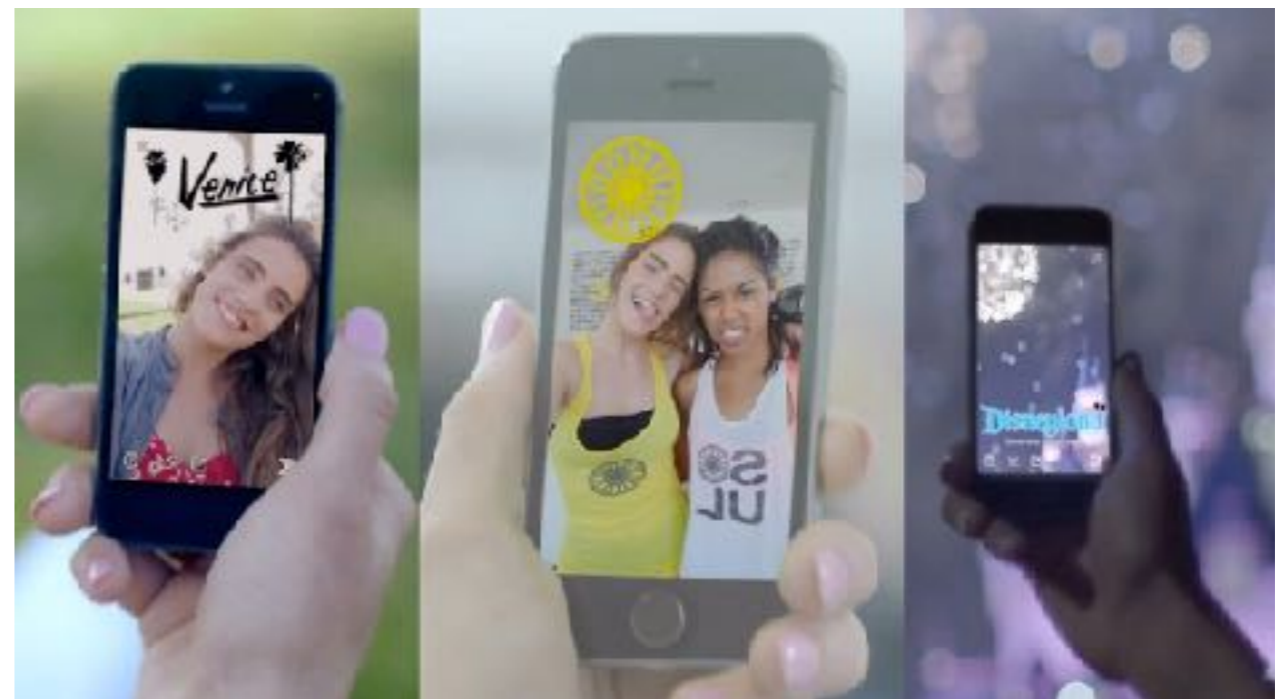

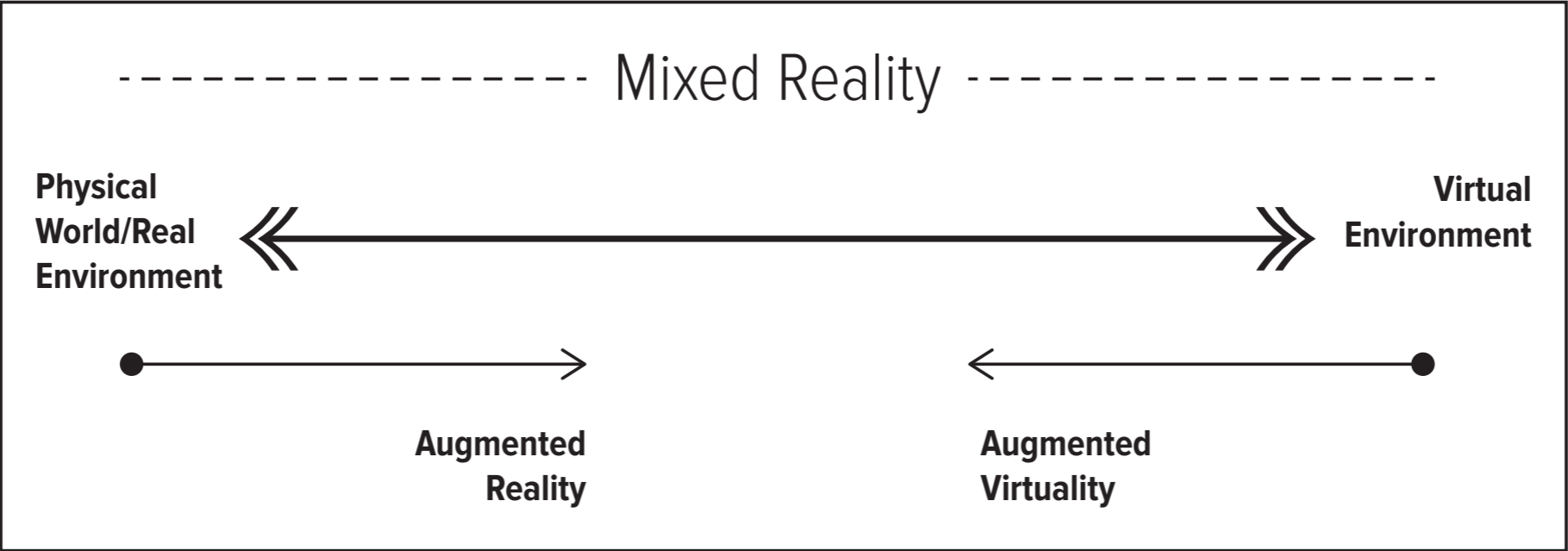

Milgram and Kishino's reality-virtuality continuum 1994

VIRTUAL REALITY (VR)

Completely digital environment

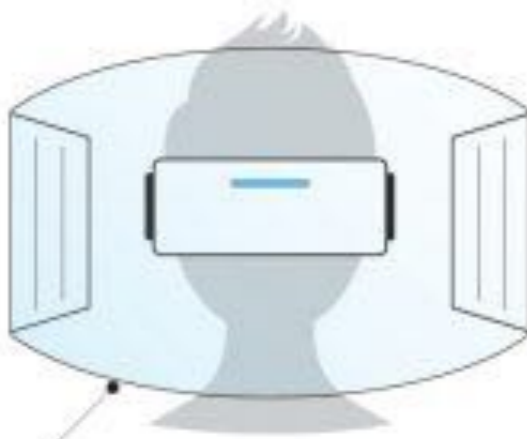
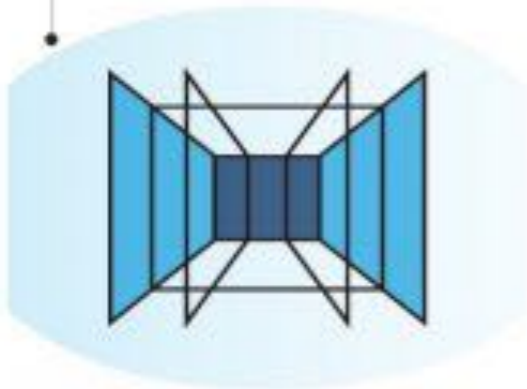

Fully enclosed, synthetic experience with no sense of the real world.

AUGMENTED REALITY (AR)

Real world with digital information overlay



Real world remains central to the experience, enhanced by virtual details.

MERGED REALITY (MR)

Real and the virtual are intertwined

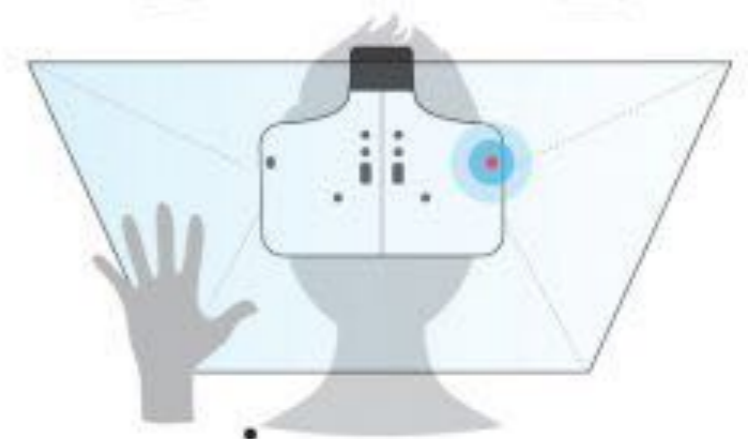
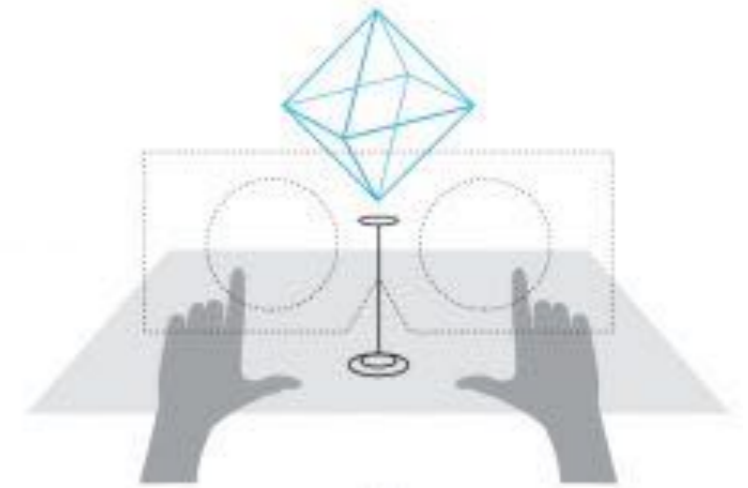

Interaction with and manipulation of both the physical and virtual environment.



Tango



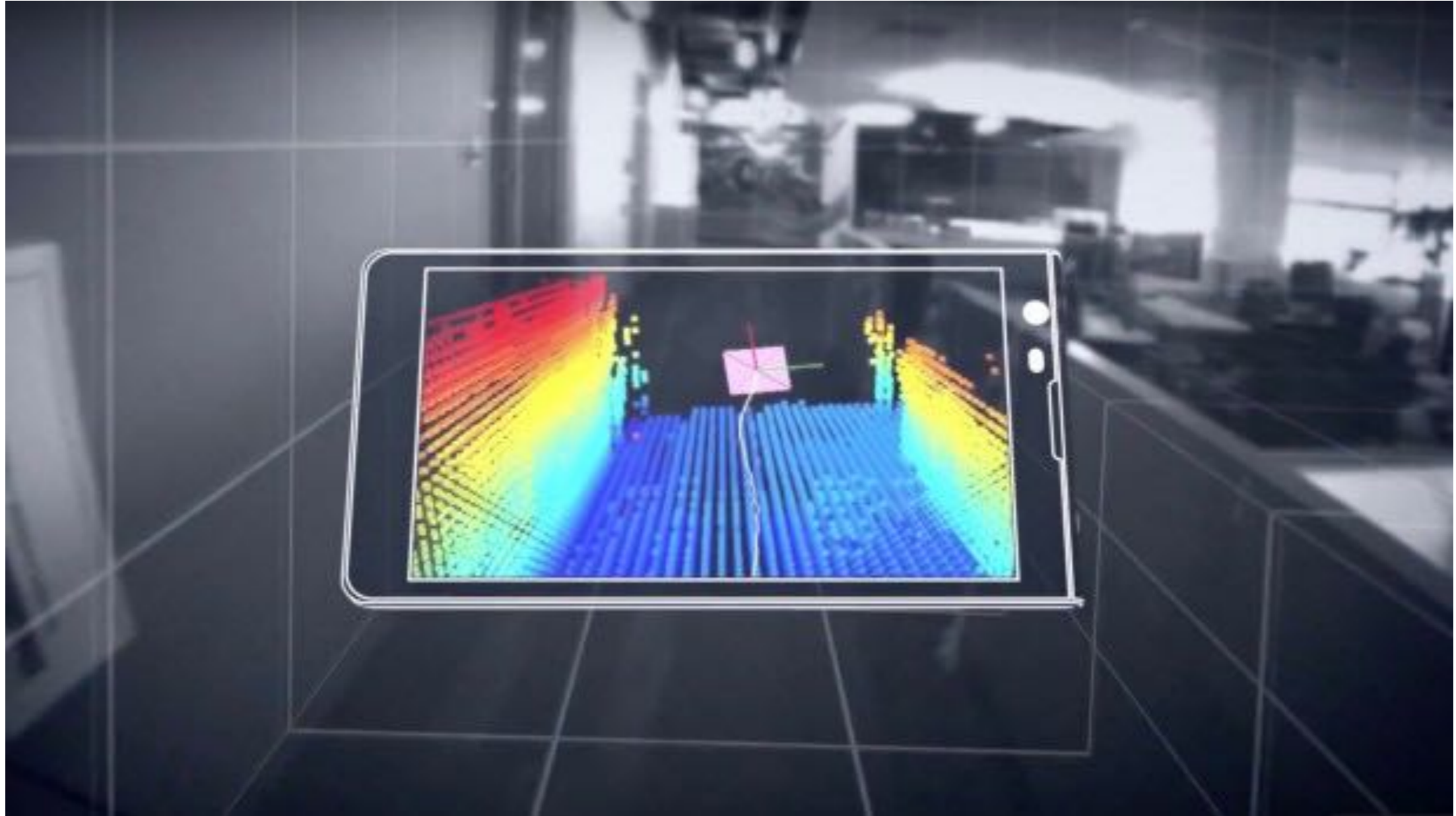

Area Learning



Motion Tracking



Depth Perception

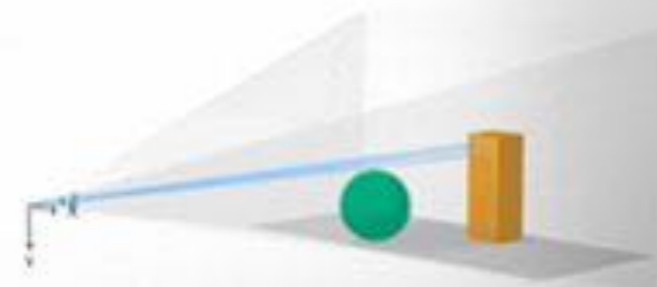

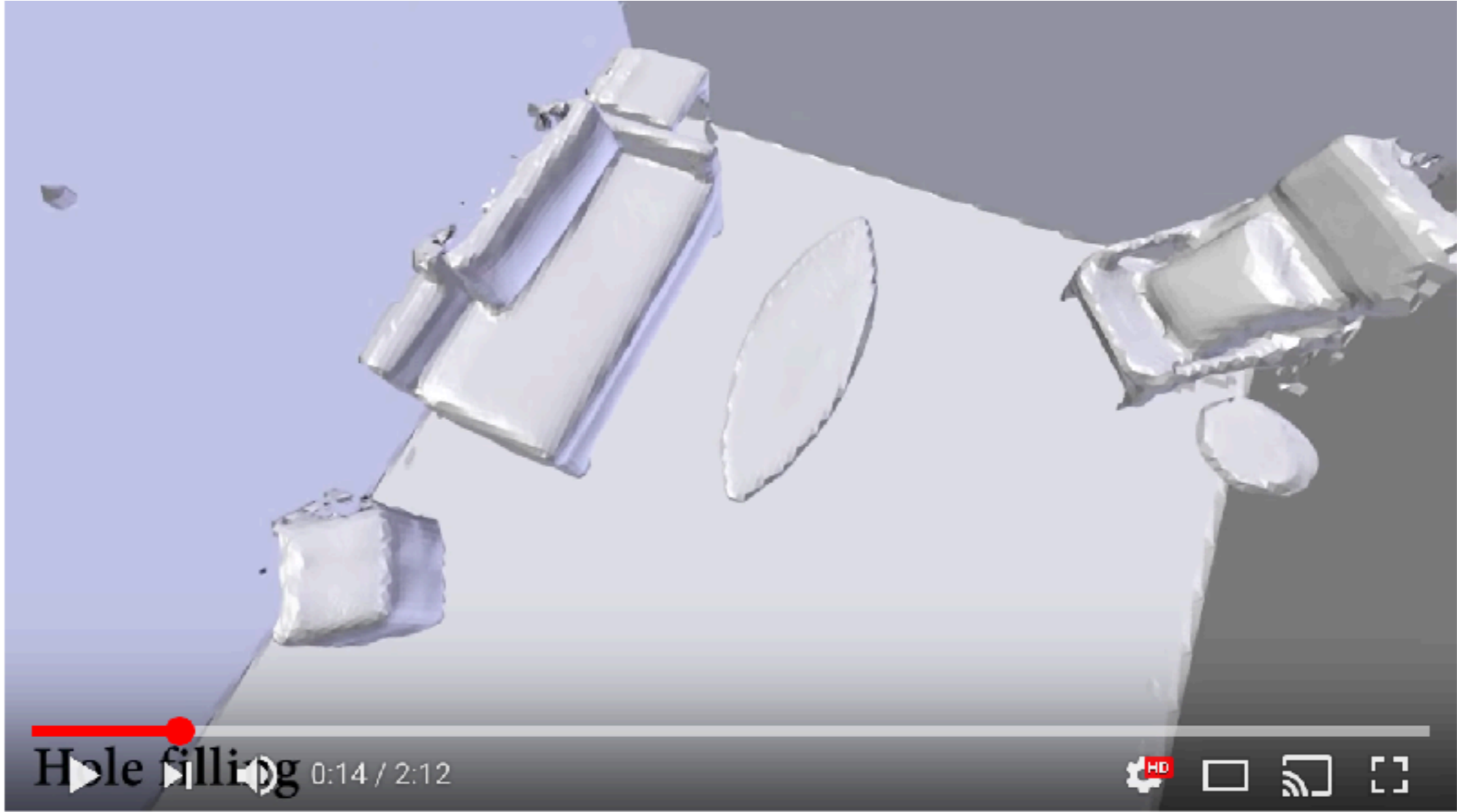



ARCore

VS.

ARKit

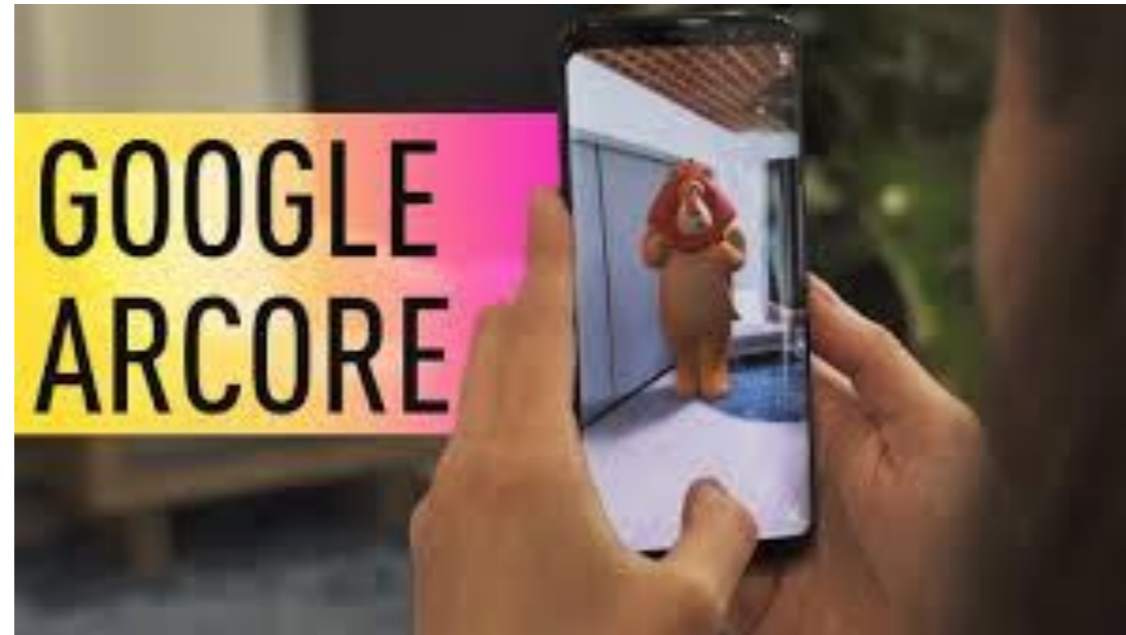

ARCore



ARCore







APPLE/THEWALKINGDEAD

Mashable

The future of iPhone apps is in augmented reality

M

0:04 / 1:51

HD

⏪ ⏩ 🔊 📺 📶 🖱️

A video player interface showing a man in a plaid shirt using an iPhone in a park. The video title is "The future of iPhone apps is in augmented reality". The player includes a progress bar, play/pause buttons, volume control, and various settings icons.



Google Lens



Here's what I found

Milk and Wine Lily

Nearby Florists

More Info

Your preset wireless settings

WiFi Network Name (SSID)



NETWORK06201994ARK

Network Key (Password)



SWPPSMBWAJB2K17#5

Network NETWORK06201994ARK

Password SWPPSMBWAJB2K17#5

NO THANKS

COPY TEXT

CONNECT



The Meatball Shop

4.2 ★★★★★

\$\$ • Italian Restaurant

Heather, Elliott and 3 others

MEATBALL

MEAT

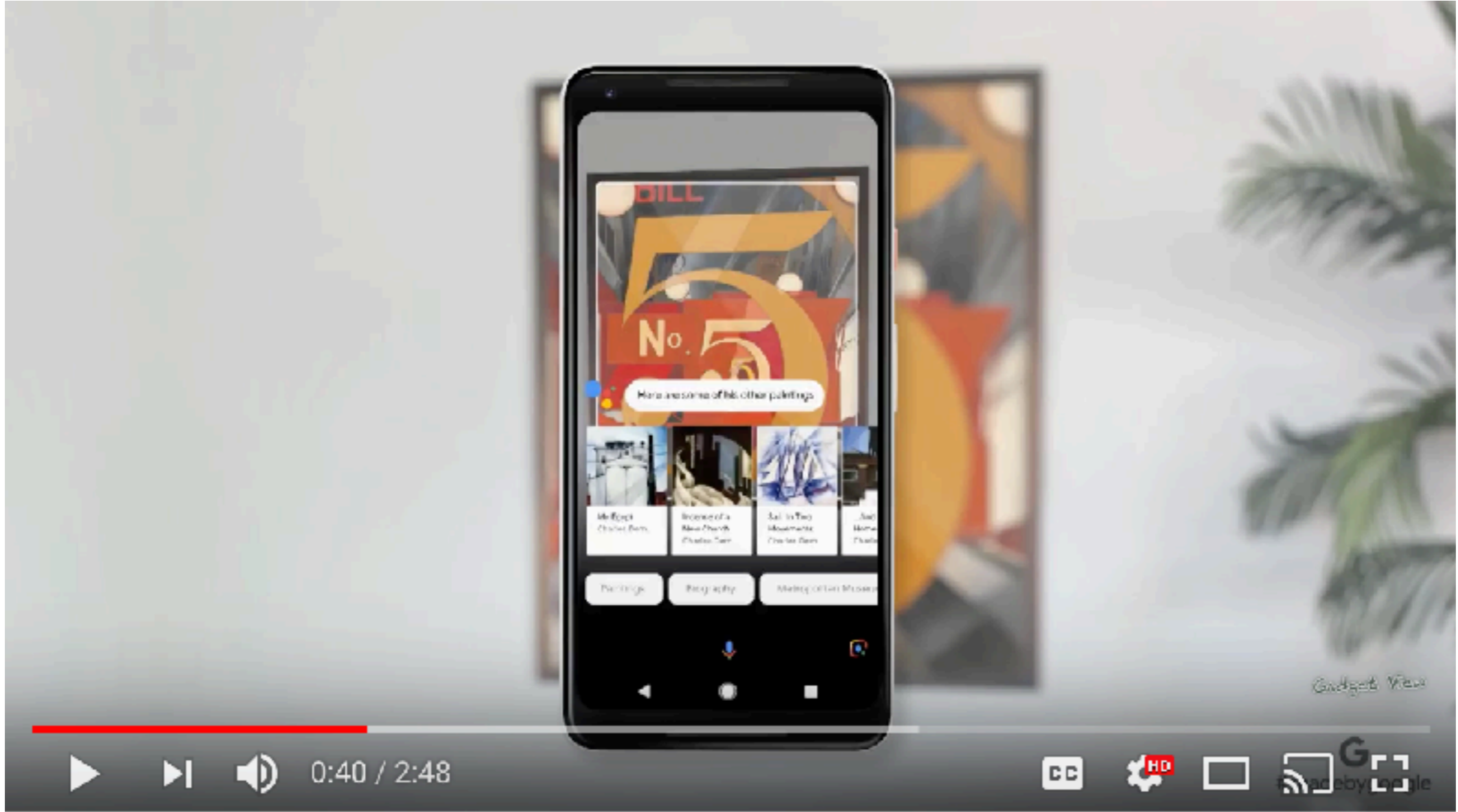

0:40 / 2:48



Gadgets View

What can I do with AR today?



© 2014 www.natebramble.com

The fisherman's lies are brought into the digital age with the aid of augmented reality.

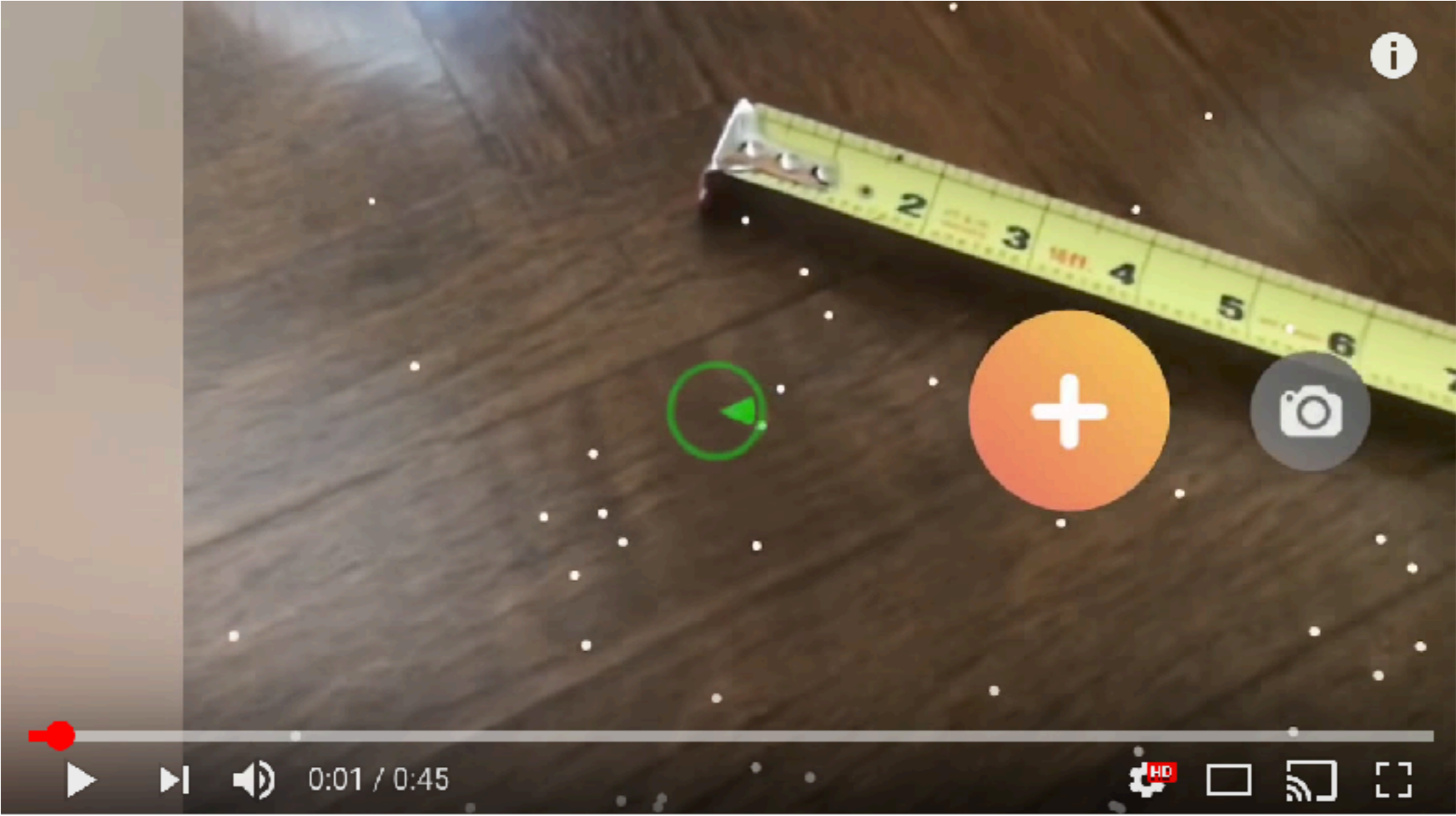

PLACE

▶ ⏪ 🔊 0:04 / 0:58

⌂ ⚙️ HD 📺 🗉



This poster has been augmented with the Aurasma App. Download the Aurasma App and scan the sections for addition content.
add user: **VisLit330** #vislit330
add user: **huisinga**

ADD USER

Click ▲ Icon



Search bar containing 'VisLit330' and a close button (X).

VIEW

1. Open the Aurasma App
2. Add new user
3. return to scan screen
4. hold over printed document

CREATE

1. Click Aurasma logo to start
2. Click Device
3. Take video/image or Select video/image (OVERLAY)
4. Point camera at Poster/Trigger image
5. Take Trigger image
6. Resize video/image to match
7. Add #VisLit330
8. Finish & Upload

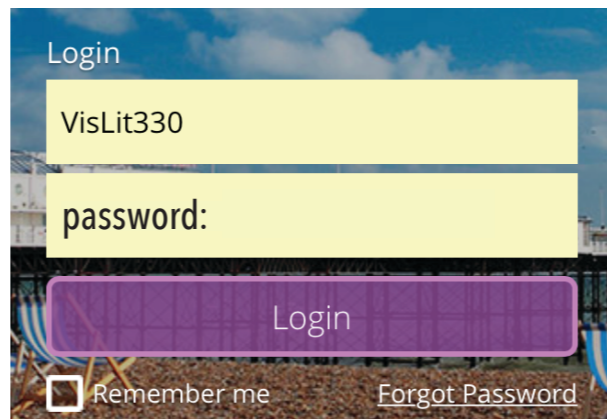

TERMS

What You Scan (POSTER)

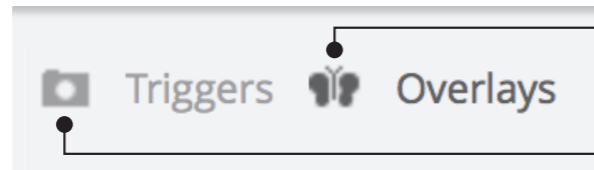

What You See (Augmented Reality)

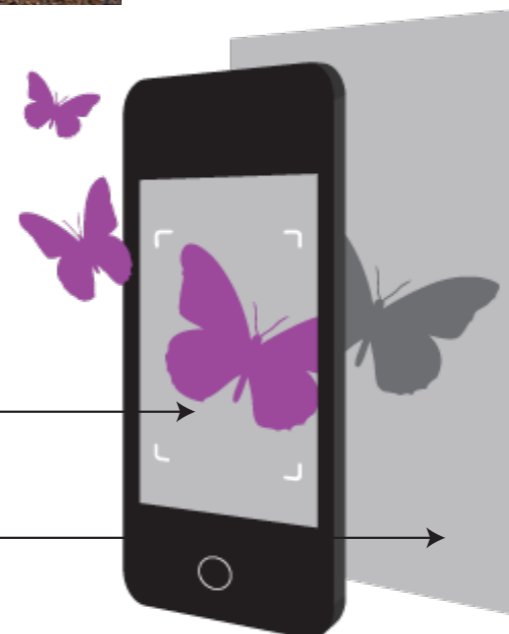

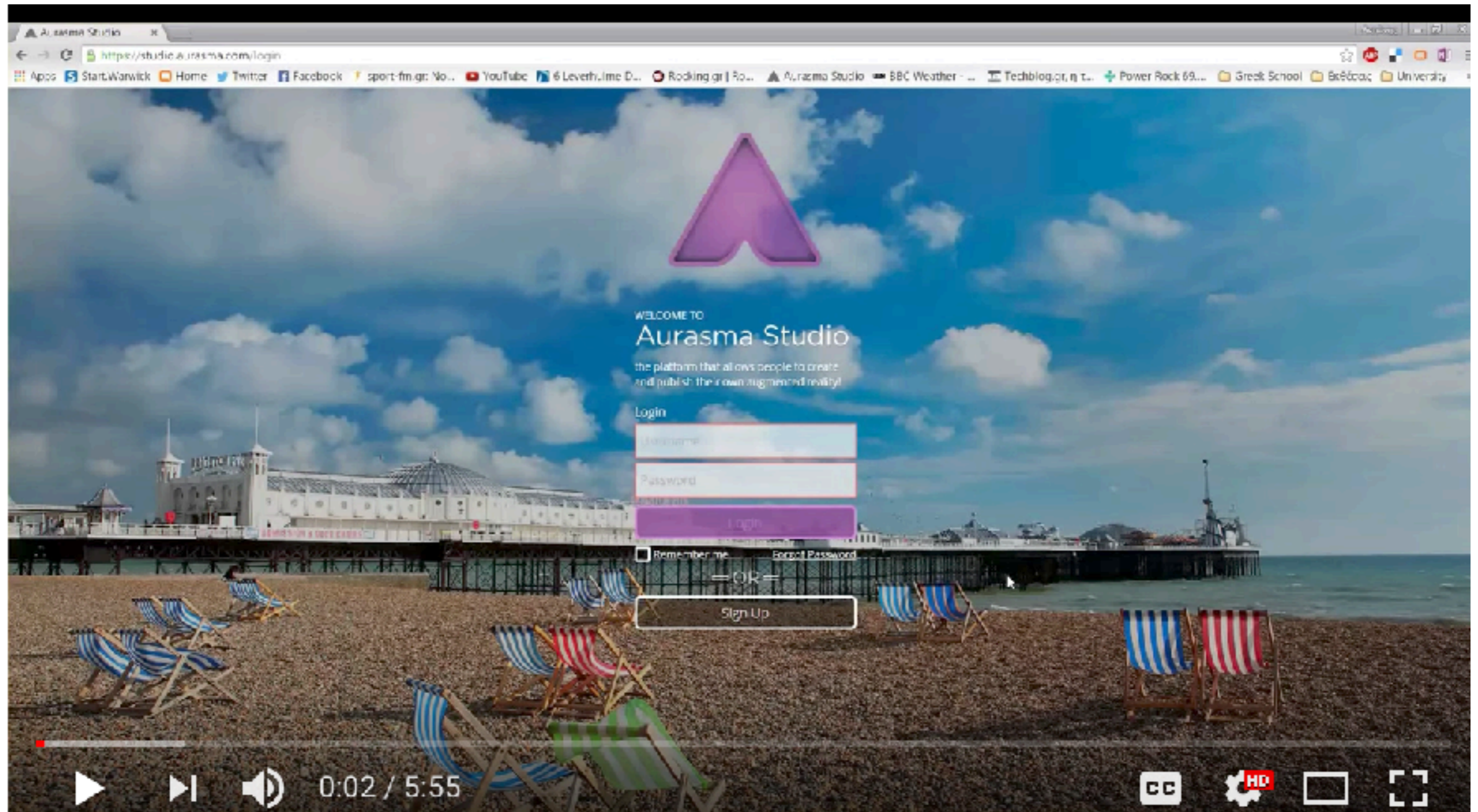

Aurasma Demo

The video player displays a smartphone screen with a star chart. The chart features the following labels: "Aquila" (with a star symbol), "SERPENS CAUDA", "SCUTUM", and "Aquila 405". The background of the chart is a night sky with a forest silhouette at the bottom. A picture-in-picture window in the bottom-left corner shows a presenter in a dark shirt, with a timestamp of "1:13". The video player interface includes a red progress bar, a timestamp of "0:57 / 4:47", and control icons for play, volume, closed captions, HD, and full screen. An information icon is located in the top right corner.

AR of Tomorrow









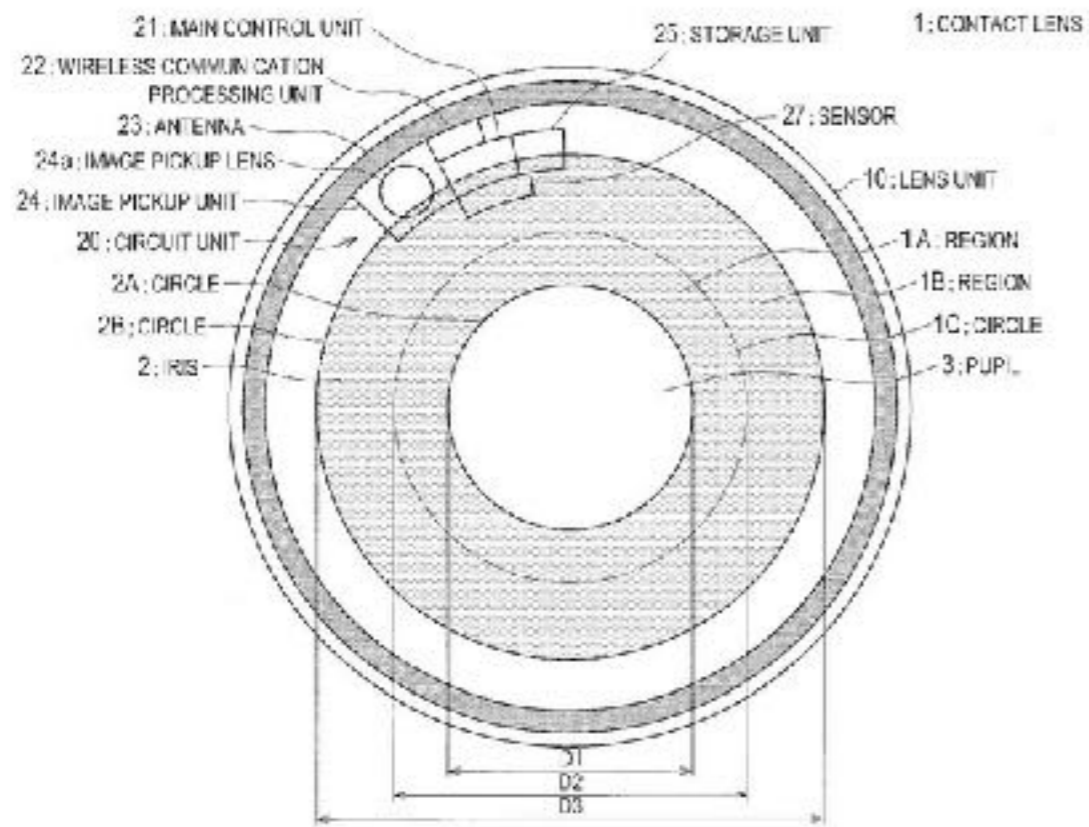

Questions?

